

# T-S24mm F3.5 ED AS UMC Instruction Manual

Thank you for purchasing T-S24mm F3.5 ED AS UMC lens. We believe that this new T-S24mm F3.5 ED AS UMC lens for video recording will give you a special photographic experience.

The T-S24mm F3.5 ED AS UMC lens is a retrofocus type lens which corrects and emphasizes the perspective, and also adjusts the depth of field. This lens completes an optical system based on superior optical technologies, and maintains excellent resolution both at the center and around the periphery of the lens by adopting a high performance Glass Molding ASP lens and a UMC (Ultra Multi Coating).

The tilt/shift unit controls the depth of field to the subject and the area for shooting. This lens compensates for image distortion and allows you to capture various images that you were never able to do with the existing lenses.

## Advantages of the T-S24mm F3.5 ED AS UMC

1. Image size of 35mm full frame.
2. It compensates for optical aberrations using a high performance aspherical lens.
3. In the fully open position, it produces a high resolution and high contrast at the center of the lens as well as around the periphery.
4. The UMC (Ultra Multi Coating) design suppresses flare and ghost images.

Since the T-S24mm F3.5 ED AS UMC lens is designed for a designated mount, you can easily take photographs without installing an additional adaptor, by mounting the lens directly onto the camera.

Please read this instruction manual carefully and use it accordingly.

\* Please read the safety precautions at the back of this instruction manual prior to use.

● Please read this instruction manual prior to use. ●

## 1. Component Names

[Figure]

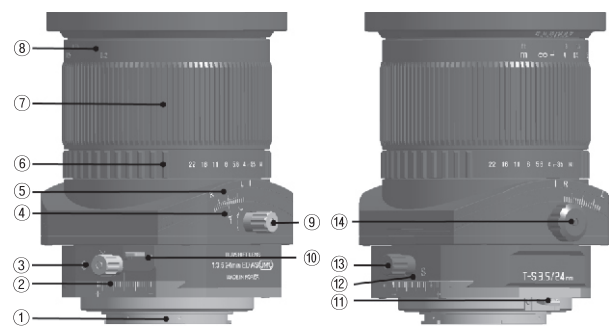

- |                       |                       |                        |
|-----------------------|-----------------------|------------------------|
| ① Mount               | ⑥ Aperture ring       | ⑪ Mount rotation lever |
| ② Shift scale         | ⑦ Focusing ring       | ⑫ Shift reference line |
| ③ Shift locking knob  | ⑧ Distance scale      | ⑬ Shift knob           |
| ④ Tilt reference line | ⑨ Tilt locking knob   | ⑭ Tilt knob            |
| ⑤ Tilt scale          | ⑩ Tilt rotation lever |                        |

## 2. Attaching to and Detaching from the Camera

When attaching or detaching the T-S24mm F3.5 ED AS UMC lens, make sure that the tilt scale and the shift scale are positioned at '0' and locked. Failure to do so will make it difficult to attach a lens to the camera since the tilt or shift part moves.

### [Attaching]

Hold the tilt area of the lens gently, align the lens mounting reference point or line with the lens ring mount of the camera, push the lens into the camera and turn the lens softly in the attaching direction until it makes a clicking sound.

### [Detaching]

Hold the tilt area of the lens gently, press the lens release button on the camera, turn the lens in the opposite direction to that for attaching, and pull it out.

## 3. Focus Adjustment

You can set the focus for a subject by turning the focusing ring when using the T-S24mm F3.5 ED AS UMC lens, as it is a Manual Focus (MF) adjustment lens. When using the tilt/shift function, you cannot check if the focus is correct using the distance scale of the lens.

If you have a camera which allows you to view images through the viewfinder or to capture a live view, check the focus while looking at an enlarged image. If you change the tilt and shift values after setting the focus, the subject will be out of focus.

### [Nikon Mount]

- ① When focusing on a subject from a far distance, turn the focus ring to the left (∞ to 0.2) and focus on the clearest subject by using the indication signal on the camera or by checking visually.
- ② When focusing on a subject from a near distance, turn the focus ring to the right (0.2 to ∞) and focus on the clearest subject by using the indication signal on the camera or by checking visually.

### [Sony α / Canon Mount]

- ① When focusing on a subject from a far distance, turn the focus ring to the right (0.2 to ∞) and focus on the clearest subject by using the indication signal on the camera or by checking visually.
- ② When focusing on a subject from a near distance, turn the focus ring to the left (∞ to 0.2) and focus on the clearest subject by using the indication signal on the camera or by checking visually.

## 4. Brightness Control

You can set the desired brightness by turning the aperture ring when using the T-S24mm F3.5 ED AS UMC lens. You can set the F NO from 3.5 to 22. When using the tilt/shift function, vignetting or slight color change may occur. Vignetting is a phenomenon where the corners of the image darkens. To reduce this, close the aperture or compensate the exposure prior to shooting. Experience is required to determine the correct exposure using the tilt/shift function. It is recommended to test shoot until you feel comfortable with the exposure.

## 5. Tilt&Shift control

The tilt/shift unit controls the depth of field to the subject and the area for shooting. This lens compensates for image distortion and allows you to capture various images that you were never able to do with general lenses.

### 5-1. Tilt control

The T-S24mm F3.5 ED AS UMC lens allows you to express the depth of field to the subject in various ways using the tilt unit. It is recommended to use a tripod for proper shooting.

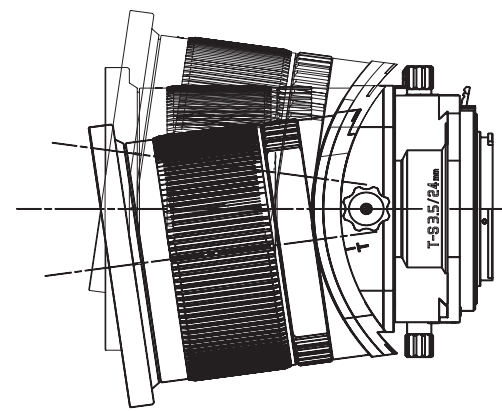

Make sure to differentiate the knob for tilting. The tilting knob is black and the locking knob is grey. Use the black knob to adjust the tilting and rotate the grey knob in L direction to hold it in place.

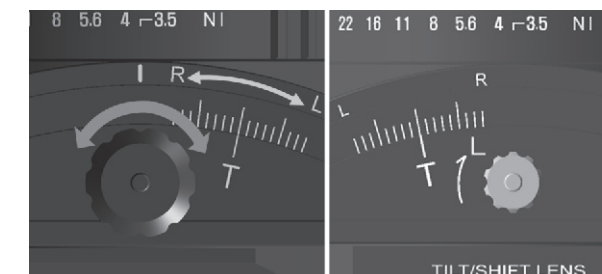

\* CAUTION  
When you use the tilt function, make sure that you do not touch the sensitive areas of the tilt unit.  
Do not turn the knobs with excessive force. Doing so may damage the knobs.

### 5-2. Shift control

The T-S24mm F3.5 ED AS UMC lens allows you to correct distortion of the subject using the shift unit. It is recommended to use a tripod for proper shooting. Make sure to differentiate the knob for shifting.

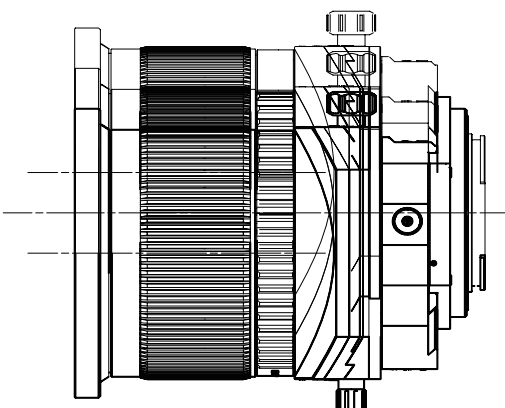

The shifting knob is black and the locking knob is grey. Use the black knob to adjust the shifting and rotate the grey knob in L direction to hold it in place.

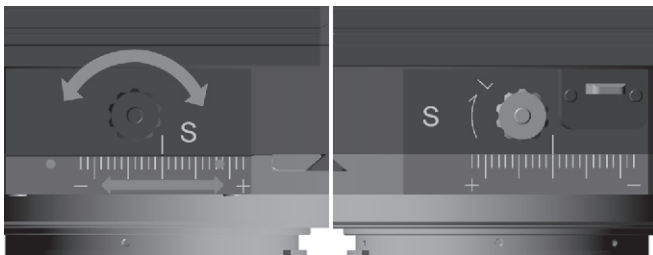

If the amount of shift is large, the lighting may be different at the top or bottom of the image or on the left or right of the image. Therefore it is recommended to shoot by reducing the aperture value.

### 5-3. Lens rotation movement

The tilt/shift direction can be changed by turning the tilt/shift unit. If you pull the mount rotation lever and the tilt rotation lever when the lens is mounted on the camera, you can rotate the tilt/shift unit. 90° rotation is available for the mount and tilt units. The lens is half secured at every 30 degrees and fully secured at 90 degrees. Please note that there is a danger of pinching your finger in the locking lever when you rotate the tilt/shift unit at a high speed. When rotation starts you can remove your hand from the rotation unlocking knob, since the rotation will continue. If the lens is secured at 90 degrees, press the knob and rotate it.

## 6. Cameras that Need Special Settings

Some cameras require special settings when using this lens.

### ○ Canon

The diaphragm of the T-S24mm F3.5 ED AS UMC Canon mount is not compatible with the camera. If the brightness value is set to above F8, the user may have difficulty in setting the correct focus by viewing a subject through the camera viewfinder. Therefore focus on a subject with a fully open aperture when attaching this lens to the camera, and then set the depth of field and brightness you want to express prior to taking the photo.

- 1) Set the camera mode dial to M.

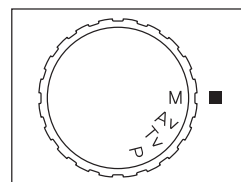

- 2) Adjust the shutter speed to achieve the appropriate exposure for the brightness.

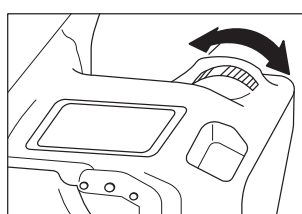

\* The shutter speed of some Canon cameras changes automatically if the shooting mode dial is set to Av and the brightness is set by turning the aperture ring. Therefore the shutter speed is not required to be set additionally as with the M mode.

(The above procedure applies to 40D. Settings for the camera or the menu may change, depending on the model or due to a menu upgrade. Therefore refer to the camera manual or contact the camera manufacturer for detailed information.)

### ○ Nikon mount

The diaphragm of the T-S24mm F3.5 ED AS UMC Nikon mount is not compatible with the camera. If the brightness value is set to above F8, the user may have difficulty in setting the correct focus by viewing a subject through the camera viewfinder. Therefore focus on a subject with a fully open aperture when attaching this lens to the camera, and then set the depth of field and brightness you want to express prior to taking the photo.

(The above procedure applies to the D8000. The settings for the camera or the menu may change depending on the model or due to a menu upgrade. Therefore refer to the camera manual or contact the camera manufacturer for detailed information.)

### ○ Sony (Minolta) α

The diaphragm of the T-S24mm F3.5 ED AS UMC Sony (Minolta) α mount is not compatible with the camera. If the brightness value is set to above F8, the user may have difficulty in setting the correct focus by viewing a subject through the camera viewfinder. Therefore focus on a subject with a fully open aperture when attaching this lens to the camera, and then set the depth of field and brightness you want to express prior to taking the photo.

- 1) Set the camera mode dial to M.

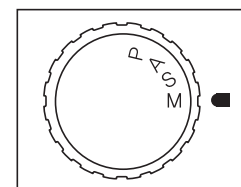

- 2) Set the focusing lever of the camera to MF.

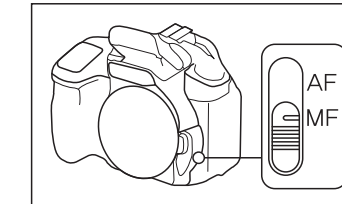

- 3) Adjust the shutter speed to achieve the appropriate exposure for the brightness.

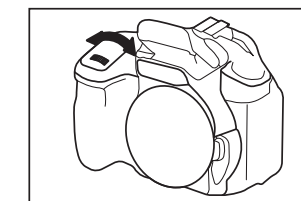

(The above procedure applies to the 350. The settings for the camera or the menu may change, depending on the model or due to a menu upgrade. Therefore refer to the camera manual or contact the camera manufacturer for detailed information.)

### ○ Mirrorless cameras (Canon M, Fujifilm X, Samsung NX, Sony E)

The diaphragms of the T-S24mm F3.5 ED AS UMC Canon M, Samsung NX, Sony E and Fujifilm X mounts are not compatible with the cameras. If the brightness value is set to above F8, the user may have difficulty in setting the correct focus by viewing a subject through the camera viewfinder. Therefore focus on a subject with a fully open aperture when attaching this lens to the camera, and then set the depth of field and brightness you want to express prior to taking the photo.

### [Canon M]

- 1) Set the exposure to manual exposure (M) and change the focus mode to MF.

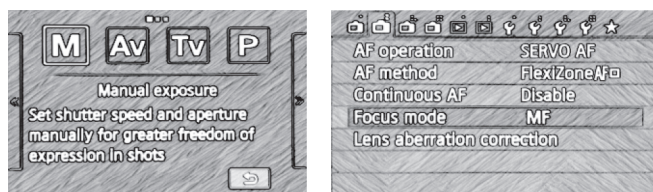

(The above procedure applies to the Canon M. The settings for the camera or the menu may change, depending on the model or due to a menu upgrade. Therefore refer to the camera manual or contact the camera manufacturer for detailed information.)

### [Fujifilm X]

- 1) Set the camera mode dial to M.

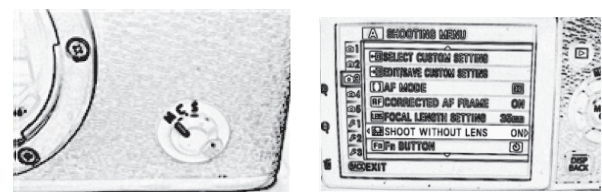

- 2) Press the MENU/OK button, and select ON at 'Shooting without lens' in the shooting menu.

(The above procedure applies to the X-Pro1. The settings for the camera or the menu may change, depending on the model or due to a menu upgrade. Therefore refer to the camera manual or contact the camera manufacturer for detailed information.)

### [Samsung NX]

- 1) Set the camera mode dial to M.
- 2) Adjust the shutter speed by turning the dial to achieve the appropriate exposure for the brightness.

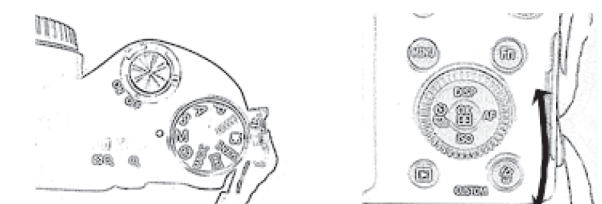

\* The shutter speed of some Samsung NX cameras changes automatically if the shooting mode dial is set to A and the brightness is set by turning the aperture ring. Therefore the shutter speed is not required to be set additionally as with the M mode.

### [Sony E]

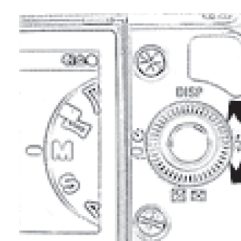

\* The shutter speed of some Sony E cameras changes automatically if the shooting mode dial is set to A, and the brightness is set by turning the aperture ring. Therefore the shutter speed is not required to be set additionally as with the M mode.

(The above procedure applies to the NEX-5. The settings for the camera or the menu may change, depending on the model or due to a menu upgrade. Therefore refer to the camera manual or contact the camera manufacturer for detailed information.)

## 7. SPEC

Focal length	24mm	
Max. aperture	F3.5 ~ 22	
Negative size	24 X 36 mm	
Angular field	35mm	83.5° (diagonal)
	APS-C (1:1.5x)	59.9° (diagonal)
Focusing range	∞ to 0.2m	
Filter connection	∅ 82mm	
Number of elements	16 Elements	
Number of groups	11 Groups	
Lens movement	Tilt max : ± 8.5° Shift max : ± 12 mm	
Lens rotation	Mount: CW 90° (30° per step)	
	Between the tilt unit and the shift unit: CW 90° (30° per step)	
Size	Canon	∅ 86 × 110 mm
	Nikon	∅ 86 × 107 mm
	Sony α	∅ 86 × 109 mm
	Canon M	∅ 86 × 136 mm
	Fujifilm X	∅ 86 × 136 mm
	Samsung NX	∅ 86 × 128 mm
Weight	Sony E	∅ 86 × 139 mm
	Canon	640 g
	Nikon	620 g
	Sony α	640 g
	Canon M	710 g
	Fujifilm X	710 g
Samsung NX	660 g	
Sony E	710 g	

## 8. Troubleshooting

Phenomenon	Causes	Solution
The lens cannot be attached to the camera.	The lens ring mount and the camera mount are not aligned.	Align the reference point on the lens with the lens attachment reference point on the camera.
The lens cannot be detached from the camera.	Incorrect rotation direction for detaching the lens. If you turn the lens while holding the camera, it may cause damage to the lens.	Hold down the lens release button on the camera, and gently turn the lens to the lens attachment/detachment reference point marked on the camera, and then pull the lens forward.
Blurry image	Incorrect focusing. Insufficient shutter speed or camera shake.	Turn the focusing ring while checking the subject with the indication on the camera or check visually to set the focus until the subject is clear, and then press the shutter. Select a shutter speed of 1/125 sec or faster, steady the camera and take a photograph.
Automatic focusing does not work properly.	A manual focusing lens has trouble with automatic focusing.	Use the focusing ring to adjust the focus.
Pictures are too dark or too bright.	Inappropriate exposure.	Adjust the aperture ring accordingly.
The camera flash is not compatible with the camera.	The manual control lens may not be compatible, depending on the camera.	See the camera manual.
There is no camera finder indication or display.	This lens does not have electrical contact points, so there is no electronic communication with the camera.	This does not indicate that there is a problem with shooting.
Zoom failure.	This lens is a single lens.	
The lens cannot be mounted on other cameras.	This lens is designed for a specific mount.	Purchase the designated lens mount.
I want to attach your ZX or iAX converter lens.	Our converter is designed for the T (M42 screw) mount only. Therefore it cannot be used with this product.	Use each company's own mount converter. Use each company's own mount converter.

## 9. Safety Precautions

The following precautions are divided into two types according to the level of danger.

**WARNING**  
If this instruction is not followed, it may cause death or severe injury to the user.

**CAUTION**  
If this instruction is not followed, it may cause death or severe injury to the user.

**WARNING**

- Don't look at the sun through the lens. It may cause blindness.
- Don't touch the lens with your fingers. If the lens is touched, it may cause damage to the lens or cause injury to the user.

**CAUTION**

- Don't touch the lens to the camera directly and don't touch the lens with your fingers. If the lens is touched, it may cause damage to the lens or cause injury to the user.
- Don't touch the lens to the camera directly and don't touch the lens with your fingers. If the lens is touched, it may cause damage to the lens or cause injury to the user.
- Don't touch the lens to the camera directly and don't touch the lens with your fingers. If the lens is touched, it may cause damage to the lens or cause injury to the user.
- Don't touch the lens to the camera directly and don't touch the lens with your fingers. If the lens is touched, it may cause damage to the lens or cause injury to the user.

**WARNING!**  
Do not wet this product or expose it to a moist environment. It may cause a fire or electric shock.

**CAUTION!**

- Do not use this product or store it close to devices that generate heat i.e., heaters, thermal regulators, stoves or stereo amplifiers.
- Do not leave the lens in conditions where drastic temperature changes can occur.
- Do not touch the surface of the lens by hand, and avoid making contact with sharp objects.
- Avoid dropping the lens.
- Do not soak the lens in water, and avoid water splashing onto the lens.
- If there are foreign bodies on the lens, use a lens cleaning kit only.
- If the lens hood is cut by the user, it may cause damage to the surface of the lens, as the surface of the lens may make contact with the floor.

## Caution! Handle with care!

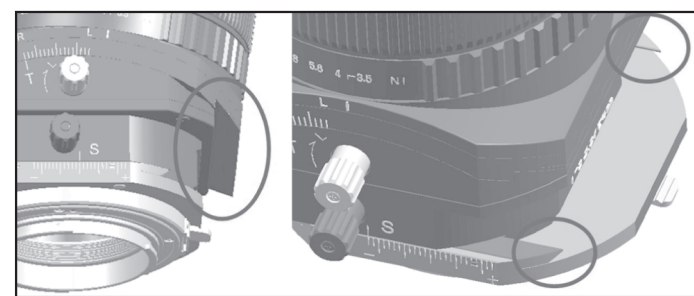

When you use the tilt or shift function, the sharp areas of the tilt and shift units become exposed. Therefore, make sure that you do not touch them or get scratched by them.

## MEMO

## MEMO

## MEMO